

AeroSys

Incorporated

Installation and Maintenance Instructions THHP-XX () Series Heat Pump Units

Congratulations on selecting a THHP-XX Unit from AeroSys. With proper installation and maintenance your system will provide you with years of satisfactory operation. This system is compatible with properly sized and laboratory listed Direct Expansion Indoor Air Handler.

IMPORTANT SAFETY INSTRUCTIONS

As a professional installer, you have the obligation to know the product better than the customer. This includes all safety precautions and related items. Prior to actual installation, thoroughly familiarize yourself with this Instruction Manual. Pay special attention to all safety warnings. Remember, it is your responsibility to install the product safely and to know it well enough to be able to instruct a customer in its safe use.

The precautions listed in this Installation Manual are intended as supplemental to existing practices. However, if there is a direct conflict between existing practices and the content of this manual, the precautions listed here take precedence.



WARNING HIGH VOLTAGE

To avoid the risk of fire or equipment damage, use only copper conductors. Disconnect ALL power before servicing or installing this unit. Multiple power sources may be present. The electrical power to this unit **MUST** be in the OFF position and all power supplies disconnected. Failure to do so may cause property damage, personal injury or death.



WARNING

The unit **MUST** have an uninterrupted, unbroken electrical ground to minimize the possibility of personal injury in an electrical fault should occur. The electrical ground circuit may consist on and appropriately sized electrical wire connecting the ground lug in the unit and control box wire to the building's electrical service panel. Other methods of grounding are permitted if performed in accordance with the *National Electric Code (NEC)/American National Standards Institute (ANSI)/National Fire Protection Association (NFPA) 70* and local/state codes. In Canada, electrical grounding is to be in accordance with the Canadian Electric Code CSA C22.1. Failure to observe this warning can result in electrical shock that can cause personal injury or death.

929 Eldridge Drive, Hagerstown, Maryland 21740
Phone: 301-620-0002 ♦ Fax: 301-620-0685
www.aerosysinc.com

Specifications are subject to change without notice.



WARNING

Installations and repair of this unit should be performed **ONLY** by individuals meeting the requirements of an “Entry Level Technician” as specified by the Air Conditioning and Refrigeration Institute (ARI). Attempting to install or repair this unit without such background may result in product damage, personal injury or death.



WARNING

This unit should not be connected to, or used in conjunction with any devices that are not designed certified for use with this unit or have not been tested and approved by AeroSys. Serious property damage or personal injury, reduced unit performance and/or hazardous conditions may result from use of devices that have not been approved or certified by AeroSys.



WARNING

To prevent the risk of property damage, personal injury or death, do not store combustible materials or use gasoline or other flammable liquids or vapors in the vicinity of this appliance.



CAUTION

Have your contractor identify all the various cutoff switches and devices that service this unit. Know where the switch is that will cut off energy to the heating system in the event of overheating.

SHIPPING INSPECTION

Upon receiving the product, inspect it for damage from shipment. Shipping damage and subsequent investigation is the responsibility of the carrier. Verify the model number, specifications, electrical characteristics and accessories are correct prior to installation. The distributor or manufacturer will not accept claims from dealers for transport damage or installation of incorrectly shipped units.

CODES AND REGULATIONS

This product is designed and manufactured to comply with national codes. Installation is accordance with such codes and/or prevailing local codes/regulations is the responsibility of the installer. The manufacturer assumes no responsibility for equipment installed in violation of any codes or regulations.



WARNING

The United States Environmental Protection Agency (EPA) has issued various regulations regarding the introduction and disposal of refrigerants. Failure to follow these regulations may harm the environment and can lead to imposition of substantial fines. These regulations may vary by jurisdiction. A certified technician must perform the installation and service of this product. Should you have any questions please contact the local office of the EPA.

REPLACEMENT PARTS

When reporting shortages or damage, or ordering repair parts, give the complete product model and serial numbers as indicated on the product label. Replacement parts for this product are available through your contractor or local distributor.

PRE-INSTALLATION INSTRUCTIONS

Carefully read all instructions for the installation prior to installing the product. Make sure each step or procedure is understood and any special considerations are taken into account before starting installation. Assemble all tools, hardware and supplies needed to complete the installation. Some items may need to be purchased locally. Make sure everything needed to install the product is on hand before starting.

Before attempting any installation, the following points should be considered:

- Structural strength of supporting members
- Clearances and provisions for servicing
- Power supply and wiring
- Air duct connections
- Drain facilities and connections

SITE PREPARATION AND INSTALLATION

To insure a satisfactory air supply, locate heat pump unit in a clean area, away from loose dirt and foreign matter that may clog the coil. The heat pump unit's outdoor coil/blower side must not be located near any exhaust of steam, hot air, grease or corrosive fumes.

The heat pump unit should be located at least 30 inches from a wall, adjacent unit or other obstruction that may restrict accessibility for maintenance. For multiple unit installations, space the units so that the hot exhaust air is not directed toward the air inlet of an adjacent unit.

Install on a solid base, capable of supporting the weight of the condensing unit. The base should be higher than the surrounding grade and larger than the dimensions of the condensing unit base.

The unit has an internal condensate drain pan with a fitting to connect to a properly trapped drain line. The internal condensate pan is sloped to drain water toward the front of the unit (maintenance access panel side).

The base of the unit is sloped to drain water away from the maintenance access side (inside face) of the equipment. When installing the unit(s), make sure to install the unit and level it to maintain the proper drainage angles.

Maximum recommended refrigerant line length is 50 feet.

Outdoor Coil Air Ducting (if used)

The total external static pressure for any inlet and outlet ducting, including louvers, must not exceed 0.3 inches of water.

If the heat pump unit draws ducted air from the outside of the building, rain hoods must be installed. In addition, install screens over the rain hood openings to eliminate the possibility of birds, water or debris entering the unit.

Normal operating sound may be objectionable if the heat pump unit is placed directly over quiet work areas. Use flexible ductwork or nonflammable cloth collars to attach ductwork to the unit to control vibration transmission to the building.

Locate the unit and ductwork so that the discharge air does not short circuit to the outdoor coil's air inlet. Avoid directing the hot exhaust air toward adjacent doors or windows.

ELECTRICAL SUPPLY AND CONNECTIONS



WARNING HIGH VOLTAGE

To avoid the risk of fire or equipment damage, **USE ONLY COPPER CONDUCTORS.**

Disconnect **ALL** power before servicing or installing this unit. Multiple power sources may be present. The electrical power to this unit **MUST** be in the **OFF** position and all power supplies disconnected. Failure to do so may cause property damage, personal injury or death.



WARNING

The unit **MUST** have an uninterrupted, unbroken electrical ground to minimize the possibility of personal injury in an electrical fault should occur. The electrical ground circuit may consist on and appropriately sized electrical wire connecting the ground lug in the unit and control box wire to the building's electrical service panel. Other methods of grounding are permitted if performed in accordance with the *National Electric Code (NEC)/American National Standards Institute (ANSI)/National Fire Protection Association (NFPA) 70* and local/state codes. In Canada, electrical grounding is to be in accordance with the Canadian Electric Code *CSA C22.1*. Failure to observe this warning can result in electrical shock that can cause personal injury or death.

Power Supply Connections

Each unit ships from the factory with all internal wiring completed. Refer to the electrical schematic when making connections.

This unit is designed for a specific electrical supply. Measure the power supply to the unit. The supply voltage must be in agreement with the unit nameplate power requirement and within the range shown in Table 1. Every installation must include an NEC (USA) or CEC (Canada) approved over current protection device. Also check with local or state codes for any special regional requirements.

Protection can be in the form of using fusing or HACR style circuit breakers. The unit nameplate can be used as a guide for selecting the Maximum Overcurrent Protection (MOP) device.

NOTE: Fuses or circuit breakers are to be sized larger than the equipment MCA but not to exceed the MOP.

A knockout is provided on the side of the unit to allow for the entry of the supply voltage conductors. If the knockout is used for electrical conduit, an adapter ring must be used in order to meet UL1995 safety requirements. An NEC or CEC approved strain relief is to be used at this entry point. The wire is to be sized in accordance with the Wire Sizing section of this manual. Some areas require the supply wire to be enclosed in conduit. Consult your local codes for applicability. Attach supply wire to unit's contactor, power distribution block or available power leads (depending on option). Route the supply power to a field supplied disconnect switch so the unit can be isolated from supply power maintenance activities.

Connect an earth ground to the lug provided in the electric junction box.

Table 1

Nominal Input	Minimum Voltage	Maximum Voltage
208/230	187	253
460	396	506

REMEMBER: THE LINE SIDE OF DISCONNECT REMAINS ENERGIZED WHEN DISCONNECT IS "OFF".

Wire Sizing

Wire sizing is important to the operation of the unit. Use the following check list when selecting the appropriate wire size for your unit.

- Wire size must carry Minimum Circuit Ampacity (MCA)
- Wire sized for no more than 2% voltage drop from the building breaker/fuse panel to the unit.

Refer to the latest edition of the National Electric Code or in Canada, the Canadian Electric Code when determining the correct wire size. The following table shows the current carrying capabilities of copper conductors rated at 75°C with a 2% voltage drop. Use Table 2 to determine the voltage drop per foot of various conductors.

Table 2

Wire Size (AWG)	Maximum allowable length in feet to Limit Voltage Drop to 2%							
	Minimum Circuit Ampacity (MCA)							
	10	15	20	25	30	35	40	45
14	75	50	37	NR	NR	NR	NR	NR
12	118	79	59	47	NR	NR	NR	NR
10	188	125	95	75	63	54	NR	NR
8	301	201	150	120	100	86	75	68
6	471	314	235	188	157	134	118	110

* Reference NEC 1996

Control Connections

A field-installed, 5-wire control connection (24VAC) is required between the indoor air handler and the heat pump unit. Control wiring must be installed in accordance with the National Electrical Code (NEC), Class 1 circuit.

Control wiring between the wall-mounted control (thermostat) and the unit must not allow a voltage drop in the line of more than 1 volt (16 gauge minimum for 75 feet).

SYSTEM OPERATION

The THHP-XX Unit uses a state-of-the-art scroll compressor specifically designed for use in a heat pump application. The unit also comes equipped with all required safety controls, blower motor, contactor and all necessary internal electrical wiring.

Cooling Mode

In the cooling mode, the THHP Unit operates like any normal air conditioning condensing unit, drawing refrigerant from the inside air handler thru the suction line and discharging the heat from the outdoor coil into the ambient air. In this mode the outdoor coils expansion device has no significant effect on the refrigerant pressure or temperature and the 3 way reversing valve is energized.

Heating Mode

In the heating mode, the indoor coil effectively becomes the condensing coil and the outdoor coil becomes the evaporator coil. Refrigerant flow passes through the expansion device in the outdoor heat pump allowing the refrigerant to vaporize in the coil and return via the compressor suction side. The 3 way reversing valve is de-energized to direct the compressor discharge refrigerant to the indoor coil (air handler) to heat the indoor space

Defrost Mode

The THHP incorporates a time/temperature defrost cycle to minimize the effect of frost accumulation on the outdoor coil when the unit is operating in the heating mode. A temperature sensing thermostat on the outdoor coil closes when the temperature reaches approximately 30°F. When the prescribed time interval between defrost cycles is met (either 30/60/90 minutes) the reversing valve is energized and a timing sequence internal to the defrost board initiated a 10 minute defrost cycle time (i.e. runs the system in a cooling mode). Once the 10 minute cycle has elapsed, the reversing valve de-energizes switching the refrigerant cycle back into heating mode and the timing cycle continues again.

Refrigerant Pressure Switches

The THHP is supplied with two (2) pressure switches for system and operator safety. The low pressure switch will open when the pressure drops below 30 psig, usually in the event of a loss of refrigerant in the system. The high pressure switch prevents the unit from operating at a discharge pressures over 400 psig, normally caused by lack of outdoor coil air flow.

- Low Pressure Switch opens at 25 psig, closes at 50 psig for R-22
- Low Pressure Switch opens at 90 psig, closes at 120 psig for R-410A
- High Pressure Switch opens at 400 psig, closes at 300 psig for R-22
- High Pressure Switch opens at 610 psig, closes at 420 psig for R-410A

REFRIGERANT PIPING CONNECTIONS

Refrigeration piping should be installed with high temperature brazed joints. ALWAYS use damp rags wrapped around the valve body to protect the valve from heat damage. Good refrigeration practices should be employed for piping supports, leak testing, dehydration, and charging of the refrigeration circuits.

Two refrigerant lines, an insulated copper suction line and a copper liquid line, are required between the evaporator and heat pump. A refrigerant drier designed for heat pumps must be installed in the liquid line. When brazing to the unit's refrigerant service valves, wrap the pipes as they penetrate the cabinet with a wet rag to prevent damage to the cabinet or internal valves.

Piping connections to the unit are mounted on the right side wall of the cabinet. The valve may be temporarily loosened from the wall to facilitate brazing. Suction lines should be insulated with minimum ½" wall insulation from the indoor coil to the compressor suction inlet.

If supplied with your system, field pressure testing, evacuation, and refrigerant charging may be done through the side ports on the suction and liquid line service valves. These ports are open to the field side of the piping. After field evacuation, open both service valves (back valve stem out) all the way for proper system operation.

Vibration isolating supports should be used to isolate the refrigeration piping from the building. Pack a soft flexible material around tubing to prevent damage when sealing openings in walls and to reduce vibration transmission.

Maximum recommended refrigerant line length is 50 feet.

Note on refrigerant Traps

When installing remote heat pump units above the indoor air handler, the suction gas line should be trapped at the indoor unit. This trap will retain refrigerant oil in the off cycle. When the unit starts, oil in the trap is carried UP the vertical riser and returns to the compressor.

When installing remote heat pump units below the indoor air handler, the suction gas line should be trapped with an inverted trap the height of the indoor air handler. This prevents refrigerant migration to the compressor during off cycles.

Charging the System

THHP-XX systems are shipped from the factory fully charged with refrigerant (R-22 or R-410A as applicable) suitable for a 15 foot run of piping between the indoor and outdoor units. If the units are placed further apart or closer together, it may be necessary to add or remove charge to obtain the proper system pressures.

To add charge the system, attach the charging hoses on the discharge and suction access ports making sure there is no air in the refrigerant hoses. A vacuum of at least 250 microns should be pulled on the system.

Break the vacuum with refrigerant in the suction line. After the pressure is sufficient to activate the low pressure switch, the compressor will turn on. Continue to charge the system, observing the refrigerant in sight glass (if applicable), the system pressures and the superheat.

Remove gauges and record pressures and temperatures comparing them to the ranges below.

Refrigerant Pressures

Suction and discharge pressures will vary with load and ambient conditions. Normal pressures in the COOLING mode are:

	R-22	R-410A
Suction pressure:	65-80 psig	100-175 psig.
Discharge pressure:	250-300 psig at 95°F	375-450 psig at 95° F
Superheat:	5-23° F	12-18° F
Sub Cooling	14-20° F	14-18° F

Optimal performance is between these ranges for the appropriate refrigerant.

R-22 Super Heat chart- Cooling mode only

Indoor Conditions			Outdoor Conditions °F									
WB	DB	% RH	65	70	75	80	85	90	95	100	105	110
80	95	53	50	49	47	46	44	43	41	40	39	37
	90	65	48	47	46	44	43	41	40	39	37	36
	85	80	47	46	44	43	41	40	39	37	36	34
78	95	48	49	47	46	45	43	42	41	39	37	36
	90	59	47	45	44	42	41	39	37	36	34	33
	85	74	45	43	41	40	38	36	34	33	31	30
76	95	43	45	43	41	40	38	36	34	32	31	29
	90	54	44	42	40	38	36	34	32	31	29	27
	85	67	42	41	39	37	35	33	31	29	27	25
	80	84	42	40	38	36	34	32	30	28	27	25
74	95	38	40	38	36	33	31	29	27	25	22	20
	90	48	40	38	35	33	31	29	26	24	22	20
	85	60	39	37	35	33	31	29	26	24	22	20
	80	76	39	37	35	32	30	28	26	24	22	19
72	95	33	38	35	33	31	29	27	24	22	20	18
	90	42	38	35	33	30	29	26	24	21	19	17
	85	54	38	35	33	30	28	25	23	21	18	16
	80	68	36	34	31	29	27	24	22	20	17	15
70	95	28	38	34	33	30	28	25	22	20	17	16
	90	38	37	34	32	29	27	24	21	19	16	14
	85	48	36	33	30	28	25	23	20	18	15	13
	80	62	33	31	28	26	23	21	18	16	13	11
	75	79	33	30	27	24	21	19	16	13	10	7
68	90	32	33	31	28	25	22	19	17	14	11	8
	85	42	32	30	27	24	21	18	15	13	10	7
	80	54	31	28	25	23	20	17	14	12	9	6
	75	70	30	26	23	20	17	14	11	8	5	5
66	90	28	30	27	24	21	18	15	12	9	5	5
	85	36	29	26	23	20	17	14	11	8	5	5
	80	48	29	26	23	20	17	14	11	8	5	5
	75	63	26	23	20	16	13	13	10	7	5	5
	70	81	26	22	19	15	12	9	5	5	5	5
64	90	24	27	24	21	18	14	11	8	5	5	5
	85	31	26	23	20	17	13	10	7	5	5	5
	80	42	25	22	19	16	13	9	6	5	5	5
	75	56	24	21	17	14	10	7	5	5	5	5
	70	72	23	19	15	12	8	5	5	5	5	5
62	85	26	20	17	13	10	6	5	5	5	5	5
	80	36	19	15	12	8	5	5	5	5	5	5
	75	49	18	15	11	7	5	5	5	5	5	5
	70	64	16	12	8	5	5	5	5	5	5	5
	65	85	13	9	5	5	5	5	5	5	5	5

Measurements should be taken within 6 inches of compressor suction inlet. White area is optimal for performance.

RECOMMENDED MAINTENANCE SCHEDULE

This unit is designed to provide many years of dependable, trouble free comfort when properly maintained. Proper maintenance will consist of annual checkups and cleaning of the internal electrical and heat transfer components by a qualified service technician. Failure to provide periodic checkup and cleaning can result in excessive operating cost and/or equipment malfunction.

Electric Panel

The electric panel should be cleaned and inspected annually for loose electrical connections

Direct Drive Blower Package

Blower impellers should be thoroughly inspected and any debris removed. Check to see if they are tightly mounted on the fan shaft and do not rub against the fan housing during rotation. Once every year add 3 drops of SAE20 weight non-detergent oil to each of the two oil ports on the blower motor if your system is supplied with oil ports

Air Distribution

Since all unit models are designed for constant volume air delivery, any unusual air flow restrictions must be avoided.

Restricted airflow through the indoor and outdoor coil will reduce the operating efficiency of the unit. Additionally, it can result in high compressor head pressure and loss of cooling. Using compressed air or a commercial coil cleaner; clean the heat pump coil of all debris that will inhibit airflow. Check for bent or damaged coil fins and repair as necessary.

Refrigerant System

Inspect all refrigerant lines and capillaries for vibration wear and support as necessary. Carefully inspect all refrigerant lines for signs of oil leaks.

The table below provides suggested service intervals of major product components for equipment in normal use. Depending on severity of the environment, you equipment may require more frequent service.

Maintenance Item	Monthly	Quarterly/ Seasonally	Semi- Annually	Annually
Check filter (if applicable)	X			
Clean condensate pan and drain		X		
Inspect unit mounting and line set connections			X	
Tighten wire connections				X
Inspect wires for wear				X
Check refrigerant charge			X	
Inspect and clean blower and motor(s)			X	
Inspect and clean coil(s)			X	
Inspect and clean condensing unit		X		
Inspect humidifier (if installed)		X		
Inspect condensate pump (if installed)			X	
Inspect UV Light (if installed)				X

UNIT INSTALLTION/START-UP CHECK LIST

- _____ Install/mount Unit, level, plumb and secure
- _____ Check for air flow restrictions or blockage (internal and external)
- _____ Pipe Unit to Air Handler
- _____ Pipe is protected from sharp, abrading edges
- _____ Install or route piping to ensure proper suction line trapping
- _____ Correct drier/strainer installed (Bi-directional for Heat Pumps, R-140A applicability)
- _____ Sight glass installed
- _____ Verify reversing valve power plug is properly seated on solenoid terminals (Heat Pumps Only)
- _____ Adjust refrigerant charge for correct superheat (heat and cooling mode for Heat Pumps; Liquid charge ONLY for R-410A units)
- _____ Seal all holes/perforations in cabinet
- _____ Unit disconnect in place
- _____ Unit properly wired and grounded
- _____ Check time setting on defrost board (select 30/60/90 minutes) for Heat Pumps
- _____ Check for detached or hanging insulation (LX Units)
- _____ Check correct thermostat wiring
- _____ Secure cabinet access panel
- _____ Turn power on

SCHEMATICS

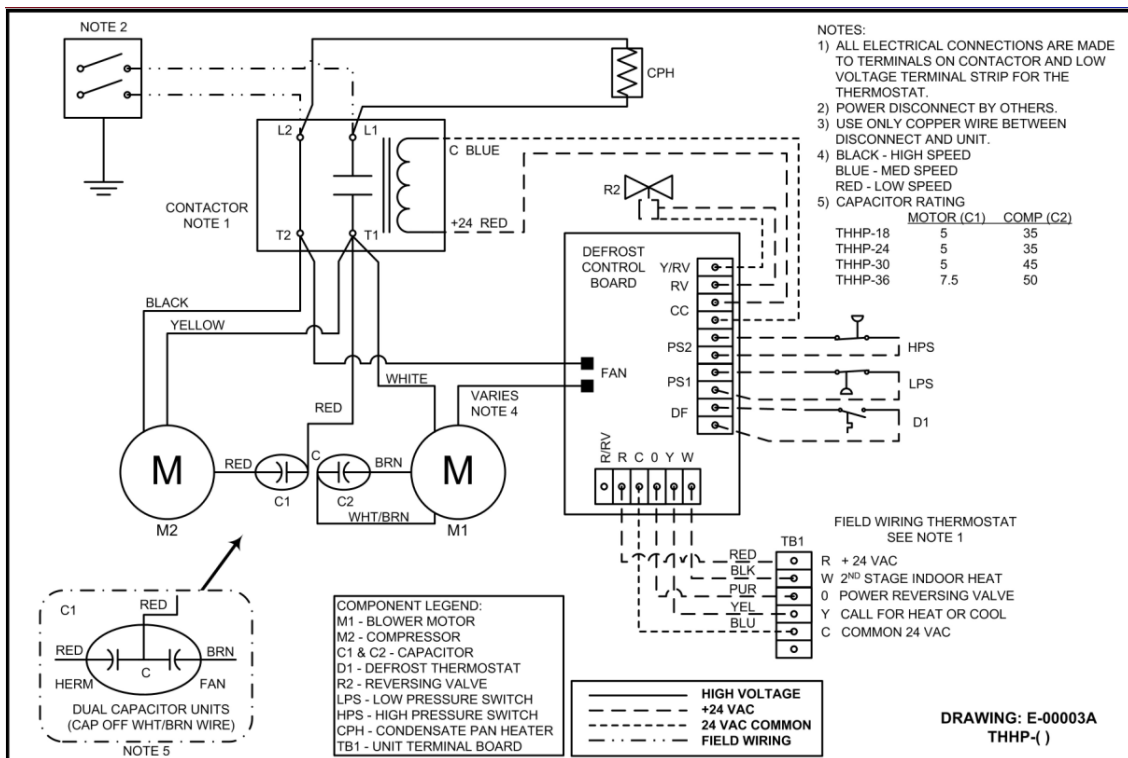

NOTE: SPECIFICATIONS AND PERFORMANCE DATA LISTED HEREIN ARE SUBJECT TO CHANGE WITHOUT NOTICE

DIMENSIONAL DATA

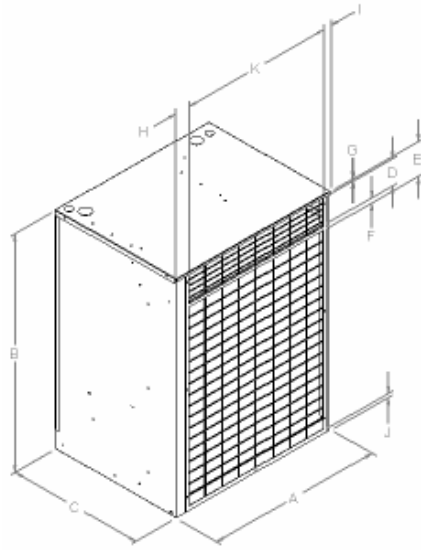

THDC/THHP-() R, S, & T

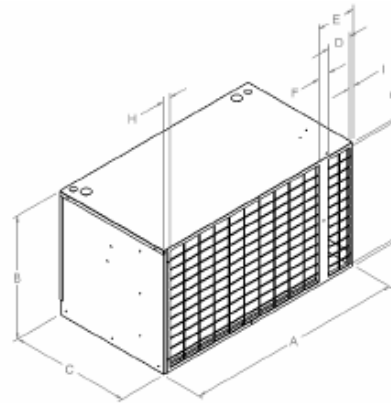

THDC-() P

Dimensions (in.)											
MODEL	A	B	C	D	E	F	G	H	I	J	K
THDC-()P	33 ¾	19	18 ½	3 ¾	6 ¾	1 ¾	½	1	¾	½	18
THDC/THHP-()R	29 ½	23	18 ½	3 ¾	4 ¾	¾	¾	1	1 ¾	½	26 ¾
THDC/THHP-()S	26	28 ¾	18 ½	3 ¾	4 ¾	¾	¾	1 ¾	1	½	23 ¾
THDC/THHP-()T	23 ¾	32	18 ½	3 ¾	4 ¾	¾	¾	1 ¾	1	½	20 ¾

➤ Specifications are subject to change.

INSTALLATION DATA

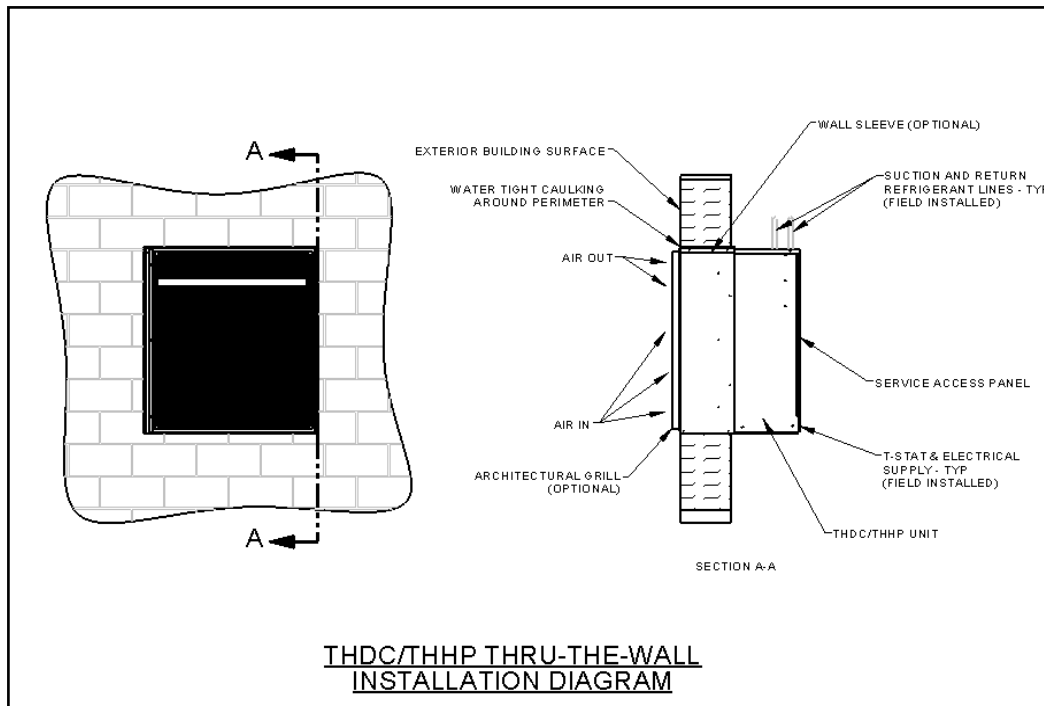

EQUIPMENT TROUBLESHOOTING GUIDE



ORIGIN or BASIS of FAILURE	Operational Issue(s)												TEST and REPAIR or REPLACE				
	Low suction pressure	Low head pressure	High suction pressure	High head pressure	System will not start	Compressor will not start	Comp. and Cond. Fan will not start	Evaporator fan will not start	Condenser fan will not start	Compressor runs - goes off on overload	System runs continuously - little cooling/heating	Too cool and then too warm		Certain areas too warm	Compressor is noisy	Unit will not terminate defrost	Unit will not defrost
Power Failure					•												Test Voltage
Blown Fuse					•	•	•										Inspect Fuse Size & Type
Unbalanced Power, 3phase					•				•	•							Test Voltage
Loose Connection					•			•		•							Inspect Connection - Tighten
Shorted or Broken Wires					•	•	•	•	•	•							Test Circuits With OhmMeter
Open Fan Overload								•	•								Test Continuity of Overload
Faulty Thermostat					•			•			•						Test Continuity of Thermostat & Wiring
Faulty Transformer					•			•									Check Control Circuit with Voltmeter
Shorted or Open Capacitor					•		•	•	•	•							Test Capacitor
Capacitor Wired Wrong (Dual Caps)					•												Verify Ground/Power Connections
Internal Compressor Overload Open							•									x	Test Continuity of Overload
Shorted or Grounded Compressor						•			•								Test Motor Windings
Compressor Stuck						•			•	•						x	Use Test Cord
Faulty Compressor Contactor							•		•	•							Test Continuity of Coil & Contacts
Faulty Fan Relay								•									Test Continuity of Coil And Contacts
Open Control Circuit								•									Test Control Circuit with Voltmeter
Low Voltage						•			•	•							Test Voltage
Faulty Evap. Fan Motor	•			x				•									Repair or Replace
Shorted or Grounded Fan Motor				•				•									Test Motor Windings
Improper Cooling Anticipator										•	•						Check Resistance of Anticipator
Shortage of Refrigerant	•	•							•	•						x	Test For Leaks, Add Refrigerant
Restricted Liquid Line	•	•		•					•	•							Remove Restriction, Replace Restricted Part
Open Element or Limit on Elec. Heater											x					x	Test Heater Element and Controls
Dirty Air Filter	•			x						•	•	•					Inspect Filter-Clean or Replace
Dirty Indoor Coil	•			x						•	•	•					Inspect Coil - Clean
Not enough air across Indoor Coil	•			x						•	•	•					Check Blower Speed, Duct Static Press, Filter
Too much air across Indoor Coil	x	•								•	•	•					Reduce Blower Speed
Overcharge of Refrigerant			•	•					•	•				•	x		Recover Part of Charge
Dirty Outdoor Coil	x			•					•	•		•					Inspect Coil - Clean
Noncondensibles				•					•	•					x		Recover Charge, Evacuate, Recharge
Recirculation of Condensing Air				•					•	•							Remove Obstruction to Air Flow
Infiltration of Outdoor Air									•	•	•						Check Windows, Doors, Vent Fans Etc.
Improperly Located Thermostat								•		•							Relocate Thermostat
Air Flow Unbalanced										•	•						Readjust Air Volume Dampers
System Undersized										•	•						Refigure Cooling Load
Broken Internal Parts															•	x	Replace Compressor
Broken Valves	•	•								•				•			Test Compressor Efficiency
Inefficient Compressor	•	•								•						x	Test Compressor Efficiency
Wrong Type Expansion Valve	•	•		x					•	•	•						Replace Valve
Expansion Device Restricted	•	•		•					•	•	•						Clear Blockage or Replace Expansion Device
Oversized Expansion Valve				•						•							Replace Valve
Undersized Expansion Valve	•								•	•	•						Replace Valve
Expansion Valve Bulb Loose				•										•			Tighten Bulb Bracket
Inoperative Expansion Valve	•								•	•							Check Valve Operation
Loose Hold-down Bolts														•			Tighten Bolts/Nuts
Faulty Reversing Valve	x	x	x					•						x	x	x	Replace Valve or Solenoid
Faulty Defrost Control	x	x	x					•						x	x	x	Test Control
Faulty Defrost Thermostat	x	x	x	x										x	x	x	Test Defrost Thermostat
Flowrator Not Seating Properly		•	•							•							Check Flowrator & Seat/Replace Flowrator
Condenser Access Panel Not In Place				•													Install Access Panel - Recheck Pressures

• cooling or heating cycle (heat pump)

x heating cycle only (heat pump)

LIMITED WARRANTY

TWO YEAR WARRANTY:

AeroSys Inc. products are warranted to be free from all manufacturing defects, material or workmanship, for a period of two years from the date of purchase (receipt required), whether or not actual use begins on this date; **or** eighteen months from the date of manufacture if the date of purchase cannot be verified, whichever is earlier.

A new unit or replacement part for any defective part will be provided without charge, provided the defective part is returned to our distributor or service department following the return instructions below.

Replacement part will assume the unused portion of the warranty.

EXTENDED COMPRESSOR WARRANTY FOR YEARS 2 THROUGH 5:

If, under normal operation, maintenance and service, the compressor fails due to a manufacturing defect, AeroSys, Inc. will provide a replacement new or remanufactured compressor.

AEROSYS INC. WILL NOT BE RESPONSIBLE FOR:

- Cost incurred for repairing, removing, shipping, servicing, installing, or handling of either defective parts or replacement parts.
- Damage or repairs required due to faulty installation or application by others.
- Start failures due to voltage conditions, blown fuses, open circuit breakers, or other damage due to the inadequacy or interruption of electrical service.
- Damage as a result of floods, winds, fires, lightning, accidents, corrosive atmosphere, or other conditions beyond the control of AeroSys Inc.
- Parts not supplied or designated by AeroSys Inc.
- AeroSys Inc. products installed outside the United States and Canada.
- Damage or repairs needed as a consequence of any misapplication, abuse, improper servicing, unauthorized alteration, or improper operation.
- ANY SPECIAL, INDIRECT, CONSEQUENTIAL, PROPERTY, OR COMMERCIAL DAMAGE OF ANY NATURE WHATSOEVER.

FOR SERVICE OR REPAIR, FOLLOW THESE INSTRUCTIONS:

- Contact the installer, contractor or the nearest distributor as they will process your claim with the factory.
- A Returned Material Authorization Number is obtained by contacting the Warranty Dept. at AeroSys. The Model Number, Serial Number & Purchase Date are required to assure the correct replacement part is selected.
- Both your purchase order number and our RMA Number are required to ship a replacement part to a customer.
- The failed part is to be returned to AeroSys, Inc. with freight prepaid.
- Items returned to AeroSys Inc. by installers or distributors for warranty claim must have a Returned Material Authorization Number attached to the part.
- Credit will be issued to the purchase order, if 1) the defective part is found to be a warranty failure & 2) it has been received at the factory within the 60 day RMA period.

INSTALLERS/DISTRIBUTERS MUST CALL AND NOTIFY THE FACTORY BEFORE A WARRANTY PART IS RETURNED. THE FAILED PART MUST BE RETURNED PREPAID WITH THE RETURN MATERIAL AUTHORIZATION NUMVERS ON ALL PARTS AND REFERENCED PAPERWORK

LIMITATION OF WARRANTIES

THIS WARRANTY IS EXCLUSIVE & IN LIEU OF ALL OTHER WARRANTIES EXPRESS OR IMPLIED. THE REMEDIES PROVIDED FOR THIS WARRANTY ARE EXCLUSIVE AND SHALL CONSTITUTE THE ONLY LIABILITIES ON THE PART OF AEROSYS INC.

Model No.: _____ Serial No.: _____ Date of Installation: _____

Extended duration warranties may apply. Contact your distributor for additional warranty information.

Effective on products manufactured after 9/1/02