



## Installation and Maintenance Instructions CeilMate™ Ceiling Mounted Air Conditioners

Congratulations on selecting a **CeilMate™** ceiling mounted air conditioner from **AeroSys**. With proper installation and maintenance, your system will provide you with years of satisfactory operation. Installation, piping, wiring and system startup should be done by qualified, experienced trade journeymen.

### Site Preparation and Installation

To ensure a satisfactory air supply for all CeilMate™ units, locate the air conditioner in a central part of the room being conditioned.

The air conditioner should be located at least 24 inches from any wall, adjacent unit or other obstruction that may restrict accessibility for maintenance. With multiple unit installations, position the units so that the conditioned air is not directed toward the return air inlet of an adjacent unit.

### Mounting the Unit

The system is normally mounted to the superstructure using  $\frac{5}{16}$  or  $\frac{3}{8}$  inch all-thread rod, passing through the mounting angle and vibration isolation mount (supplied with the unit). See page 11 in the back of this manual for dimensional information.

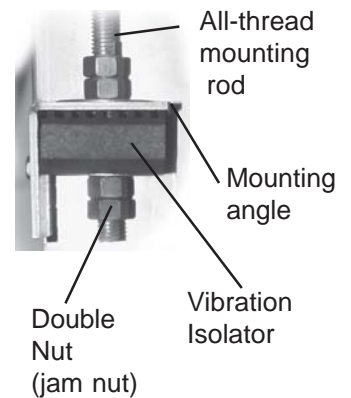

### *System View*

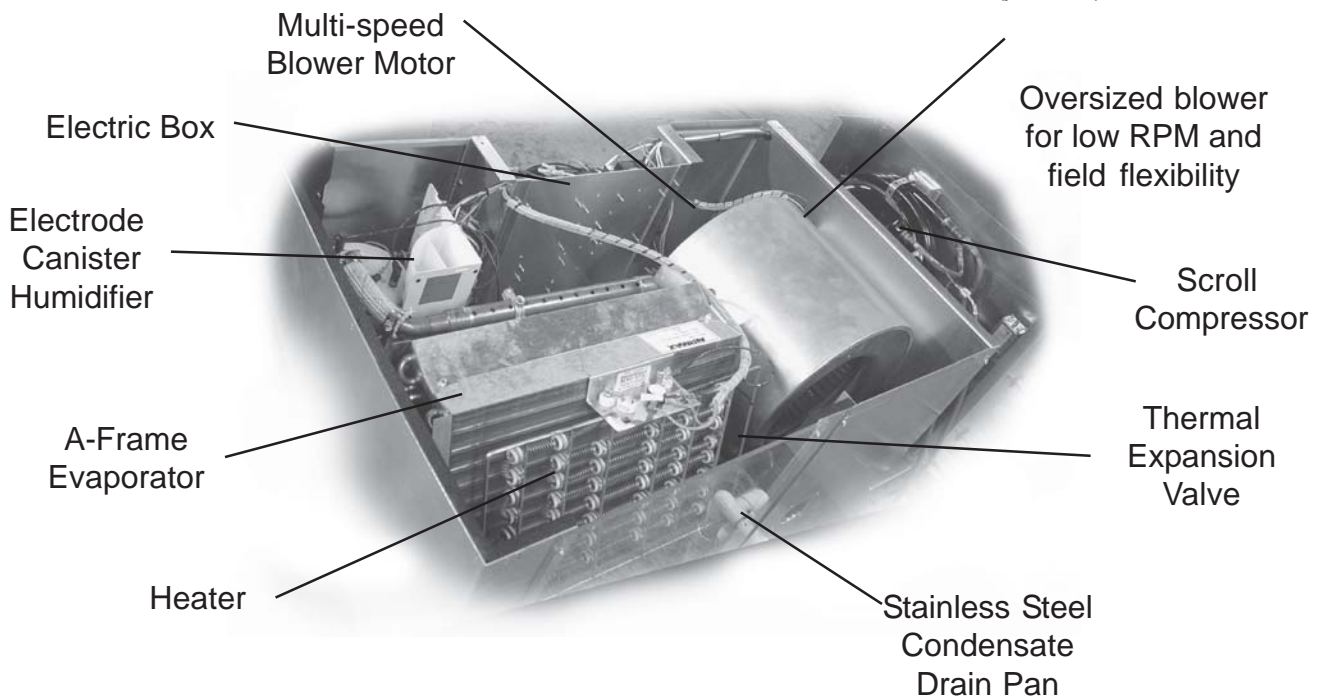

**Be sure to secure the unit by using double (jam-nuts) and/or locking nuts**

Lower the unit onto the foam cushion between the supply/return grille assembly and the bottom flange of the CeilMate™ system (see picture).

**Condensate Drain**

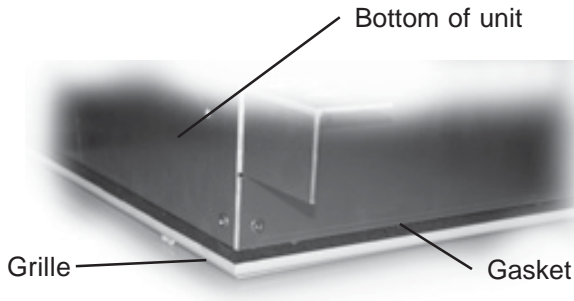

The condensate drain connection is PVC-type plastic pipe. The drain connection is located on the side of the unit opposite the electric box.

The condensate drain trap must be properly designed to ensure the removal of condensate; incorrect trapping can hold water in the pan causing system shut down, or possible condensate overflow. Be sure the external condensate drain line pitches downward at a slope of one inch every ten feet.

When installing make sure to properly level the unit to maintain the proper condensate drainage.

**Air Cooled Condenser Air Ducting** (if used)

The total external static pressure for the condenser inlet and outlet ducts, including any grilles, must not exceed 0.3 inches of water.

If the air conditioner draws ducted air from the outside of the building, rain hoods must be installed. In addition, install screens over rain hood openings to eliminate the possibility of birds, water, or debris entering the unit.

Use flexible ductwork or nonflammable cloth collars to attach ductwork to the unit and to control vibration transmission to the building, especially if the air conditioner is placed directly over quiet work areas.

Locate the unit and ductwork so that the discharge air does not short circuit to the outdoor coil's air

inlet. Avoid directing the exhaust air toward adjacent doors or windows.

**Electrical Connections**

All power and control wiring and ground connections must be in accordance with the National Electrical Code and local codes. Refer to unit nameplate for voltage, wire size and circuit protection requirements.

**USE COPPER CONDUCTORS ONLY**

***! WARNING!***

***UNIT CONTAINS HAZARDOUS ELECTRICAL VOLTAGE. DISCONNECT POWER SUPPLY BEFORE WORKING ON IT. THE LINE SIDE OF DISCONNECT REMAINS ENERGIZED WHEN DISCONNECT IS "OFF"***

Each unit ships from the factory with all internal wiring completed. Refer to the electrical schematic when making connections.

Electrical connections necessary for the air conditioner at the installation site are:

- 1) Power supply to the air conditioner line side electrical distribution block,
- 2) 24 VAC Control wiring between the wall-mounted control and the air conditioner, connected to the air conditioner terminal board.

**Control Connections**

A field-installed, 4-wire control connection (24VAC) is required between the wall-mounted control and the air conditioner (7-wires are required with the humidification/dehumidification option). Control wiring must be installed in accordance with the National Electrical Code (NEC), Class 1 circuit.

Control wiring between the wall-mounted control and the air conditioner must not allow a voltage drop in the line of more than 1 volt (16 gauge minimum for 75 feet).

**Power Connections**

The air conditioner requires its own high voltage (208-220 Volt) power source and earth ground, with a disconnect switch (field supplied) to isolate the unit for maintenance. Route the supply power to the disconnect switch and then through the cabinet's power inlet hole and then to the unit's distribution block.

Connect an earth ground to the lug provided in the electric junction box.

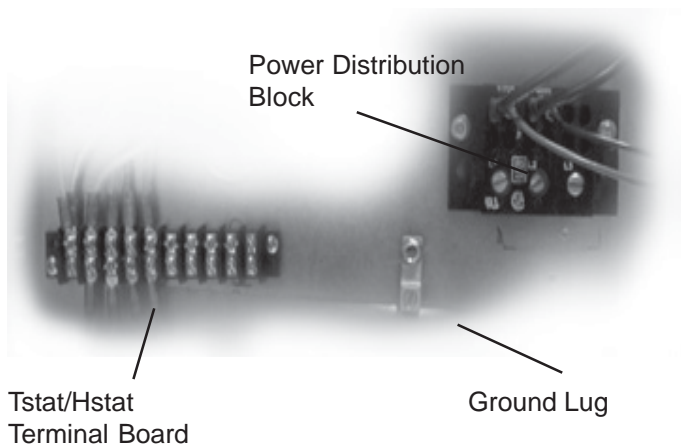

### **Refrigerant Piping Connections**

Self contained air cooled, water cooled and glycol cooled systems do not require refrigerant piping in the field. These systems are factory charged with the correct amount of refrigerant and do not require additional R-22 to be added.

#### **Split Refrigerant Systems**

Maximum recommended refrigerant line length is 50 feet.

Refrigeration piping should be installed with high temperature brazed joints. ALWAYS use damp rags wrapped around the valve body to protect the valve from heat damage. Good refrigeration practices should be employed for piping supports, leak testing, dehydration, and charging of the refrigeration circuits.

Two refrigerant lines, an insulated copper suction line and a copper liquid line, are required between the evaporator and the air conditioner. When brazing to the unit's refrigerant service valves, wrap the pipes as they penetrate the cabinet with a wet rag to prevent damage to the cabinet or internal valves.

If supplied with your system, field pressure testing, evacuation, and refrigerant charging may be done through the side ports on the suction and liquid line service valves. These ports are open to the field side of the piping.

Vibration isolating supports should be used to isolate the refrigeration piping from the building.

Pack a soft flexible material around tubing to prevent damage when sealing openings in walls and to reduce vibration transmission.

### **NOTE ON REFRIGERANT TRAPS**

*When installing remote air conditioner units above the indoor air handler, the suction gas line should be trapped at the indoor unit. This trap will retain refrigerant oil in the off cycle. When the unit starts, oil in the trap is carried UP the vertical riser and returns to the compressor.*

*When installing air conditioner units below the indoor air handler, the suction gas line should be trapped with an inverted trap the height of the indoor air handler. This prevents refrigerant migration to the compressor during off cycles.*

### **System Operation**

CeilMate systems use state-of-the-art scroll compressors specifically designed for use in air conditioner applications.

#### **Cooling mode**

When the thermostat calls for cooling, the 24VAC signal passes through the high and low pressure safety switches, causing the compressor contactor closure.

In split systems, the 24VAC thermostat signal activates the pump-down solenoid on a thermostat call and the compressor contactor operates through the closure of the low pressure switch.

#### **Heat/reheating Mode**

Electric reheat is designed to offset the cooling effect of the dehumidification cycle; electric heat provides resistance heat, regardless of the dehumidification cycle. The unit incorporates a factory installed, wired and tested Nichrome wire heater. Each heater bank has two thermal safety cutouts, one pilot duty automatic resettable and a second power line fuse link (over-temperature) safety device.

The heater(s) is energized on a call for heat from the wall mounted thermostat. The control circuit (24vac) is routed through the pilot duty (with automatic reset) high temperature thermostat. The high voltage power lines are routed through one-

time fuse links to the high voltage terminals on the heater bank(s).

High Voltage Fuselink

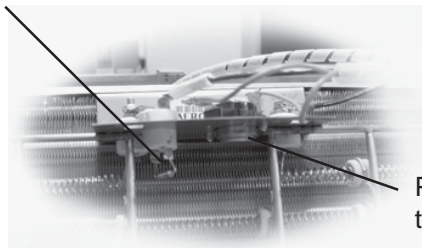

Pilot voltage thermostat

Refrigerant Pressure Switches

The system is supplied with 2 pressure switches for system and operator safety. The low pressure switch will open when the pressure drops below 30 psig, usually in the event of a loss of refrigerant in the system. The high pressure switch prevents the unit from operating at discharge pressures over 400 psig, normally caused by lack of outdoor air flow.

Normal pressures are:

Suction pressure switch	30 psig open
	70 psig close
Discharge pressure switch	400 psig open
	300psig close

Refrigeration piping should be installed with high temperature brazed joints. ALWAYS use damp rags wrapped around any valve bodies to protect the valve from heat damage. Good refrigeration practices should be employed for piping supports, leak testing, dehydration, and charging of the refrigeration circuits.

Vibration isolating supports should be used to isolate the refrigeration piping from the building. Pack a soft flexible material around tubing to prevent damage when sealing openings in walls and to reduce vibration transmission.

Charging the System

Self contained systems are shipped from the factory fully charged with refrigerant R-22. Split systems are evacuated and shipped with a dry nitrogen charge from the factory.

To charge the system, attach the charging hoses on the discharge and suction access ports, making sure there is no air in the refrigerant hoses. A

vacuum of at least 250 microns should be pulled on the system.

Break the vacuum with refrigerant in the suction line. After the pressure are sufficient to activate the low pressure switch, the compressor will turn on. Continue to charge the system, observing the refrigerant sight glass, the system pressures and the superheat.

When the sight glass bubbles begin to clear stop charging for a few minutes and allow the system to stabilize. If bubbles reappear, add a little more refrigerant (a few occassional bubbles are ok).

Remove gauges and record pressures and temperatures comparing them to the ranges below.

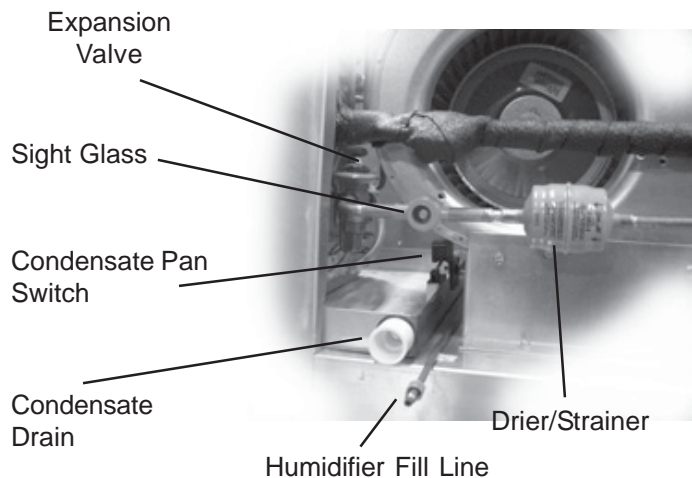

Refrigerant Pressures

Suction and discharge pressures will vary with load and ambient conditions. Normal pressures in the COOLING mode are:

Suction pressure	65-80 psig.
Discharge pressure	210-300 psig at 95° F
Superheat	6-12° F

Air Cooled Systems:

Self-contained CM-( )-AS

Air Cooled systems do not require any additional refrigerant attention as the system is factory charged and tested. The system incorporates a condenser fan speed control for head pressure control between 220-275 psig discharge pressure. As the head pressure rises to 275 psig, the fan speed increases to reduce head pressure; conversely, as the pressure falls to 220 psig the

fan slows to increase or maintain head pressure. The head pressure switch is located in the condenser inlet air stream as shown in the following picture.

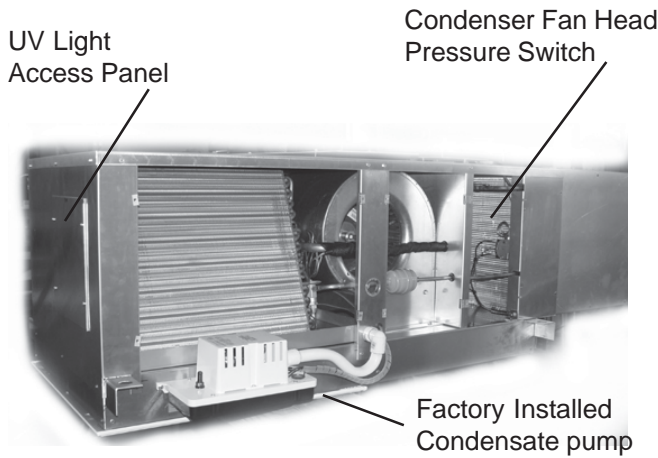

Access panels are removed for clarity

Manual Flushing

To clear any sediment that might accumulate, valves may be manually flushed. Insert screwdrivers under both sides of the valve spring guide and lift upwards to flush the valve. Manual flushing does not affect valve adjustment.

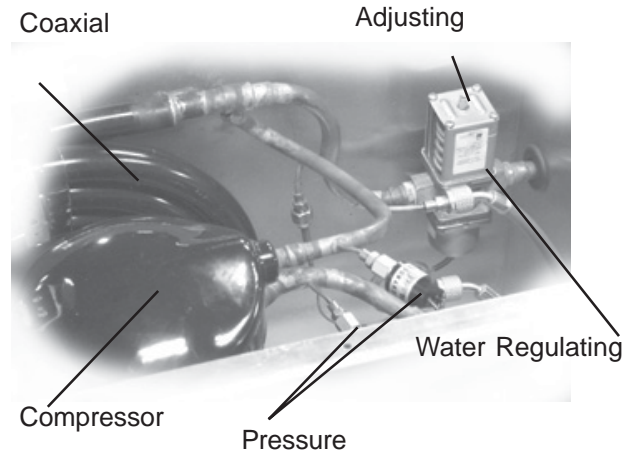

Water/Glycol Systems

Water Piping

All piping must be supported independent of coils. Swing joints or flexible fittings must be provided to absorb expansion and contraction strains. Rigid piping reduces the effectiveness of vibration isolators. The water supply should always be connected so that the entering water is on the leaving air side of the condenser coaxial coil. Isolation valves are strongly suggested to facilitate future service work.

Adjustment – Water Regulating Valve

All valves are factory set during the test process. Pressure settings are:

- Water Cooled            210 psig
- Glycol Cooled           280 psig

Valves may be adjusted with standard service valve wrenches or screwdrivers (see figure). All range valve settings can be changed quickly. To raise the valve opening point, turn the adjusting screw, located at the top of range spring housing, counterclockwise. Turn the adjusting screw clockwise to lower the opening point. Exact settings can be made using a pressure gauge in the refrigerant line to determine the throttling point. Put the system under normal operating load and adjust to the desired operating pressure. connected so that the entering water is on the leaving air side of the condenser coaxial coil.

Chilled Water Systems

Chilled water systems incorporate a 24VAC water control valve to provide on/off water flow in response to demand for cooling. The motorized control valve is located in the conditioned air section of the unit and is accessible through the labeled access panel. The valve opens on demand for cooling and closes on the thermostat signal or loss of power to the valve. Isolation valves are strongly suggested to facilitate future service work.

Chilled Water Regulating Valve

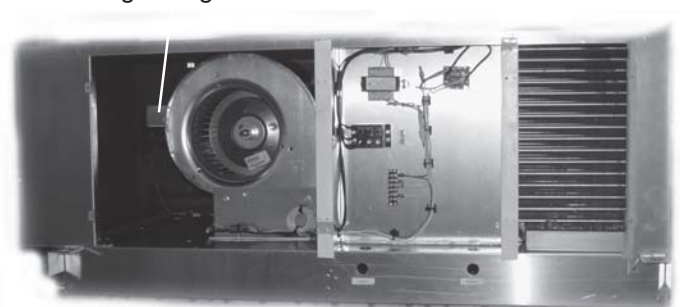

Access Panels are removed for clarity

## **Electrode Canister Humidification Option**

### PRINCIPALS OF OPERATION

When the humidistat calls, the cylinder fills to 110% of the Full Load Amperage (F.L.A.) or to the top of the cylinder, whichever comes first.

If it reaches 110% F.L.A. the water heats and boils away to a level giving 90% F.L.A.

An electronic timer uses the rate of amp fall to determine the water level. The objective is to concentrate current-carrying minerals in the cylinder so that a small volume of water is required to produce the rated steam output.

This achieves the longest life for the disposable cylinder because of minimal electrode coverage and use of less energy because the high concentration allows a minimal drain rate.

When 90% F.L.A. is reached, the fill valve will open refilling cylinder to 110% F.L.A. On occasion, the drain valve will also come on if water level is too low, indicating too high a concentration and the requirement for a dilution of the water in the cylinder.

If the water reaches top of cylinder before 110% F.L.A., the fill valve shuts off via the sensor and fill-boil-fill-boil cycle continues, cycling off the red high water sensor light until the concentration becomes high enough to reach 110% F.L.A. The above described control process will then take over.

### WATER SUPPLY AND PLUMBING

1. The orifice in the fill valve is sized for an extended water pressure range of 30 to 85 psi.
2. For water pressure between 15 and 30 psi, notify the factory and the next larger size fill valve will be supplied.
3. For cases below 15 psi, notify the factory and a fill valve with an oversized orifice will be supplied.
4. For cases above 85 psi, install a pressure reducing valve in the water feed line to the unit.
5. With extremely dirty or muddy water sources, e.g., some well sources, ensure proper filtration by adding an external filter to the water line entering the unit. (Consult factory for accessories such as filters.)

6. DO NOT use completely de-mineralized water with this unit as it is the minerals that allow the electrode principle to work.
7. DO NOT use a hot water source as it will cause deposits that will eventually block the fill valve orifice.

### WATER CONNECTION

1. A copper compression olive type coupling for ¼" O.D. soft copper tubing is provided with unit and requires no soldering for the water connection to the unit. See Figure #2.
2. An isolating valve should ALWAYS be placed in the feed water line allowing service of the fill valve.
3. Each unit is fitted with a fill solenoid valve located on the base drain pan. Flow orifices are designed for water pressure from 30 to 85 psi and are protected by the built-in strainer.
4. For inlet water pressure outside this range, the factory should be contacted. (See Water Supply and Plumbing section of this manual.)

### HUMIDIFIER START-UP AND OPERATION

Check to see that the unit is securely mounted on a level surface with the proper drain and water supply. Check for correct voltage with appropriately sized service. Check that the steam distributor, steam supply hose, and condensate line are correctly installed and routed back to the unit. Ensure that the external control humidistat is located in an area to properly sense the relative humidity to be maintained by the humidifier, and that the interconnecting low voltage wires between the humidistat and the unit's control terminal strip are in accordance with the wiring diagram.

Check all electrical connections for wires which may have become loose in shipping. Components damaged due to loose connections are NOT under warranty.

Check electrode plugs to ensure they are pressed firmly onto the electrode pins. Important: Loose connections will cause overheating of the cylinder plugs, possibly melting the plugs and/or cylinder. Open the isolating valve in the feed water line to the unit.

Make sure the humidistat is set high enough to call for humidification.

Turn on the main disconnect switch in the primary service feeding the unit and check that unit has power at the primary terminal block.

PUSH THE AUTO ON/OFF DRAIN SWITCH TO "ON".

Water will start to enter the cylinder through its bottom port and rise in the cylinder to a point determined by the solid-state control circuitry.

## Recommended Maintenance Schedule

Each year the components of the refrigeration system should be inspected for proper function and signs of wear. Since in most cases evidence of malfunction is present prior to component failure, periodic inspections can be a major factor in the prevention of most system failures.

### Electric Panel

The electric panel should be cleaned & inspected annually for any loose electrical connections.

### Direct Drive Blower Package

Blower impellers should be thoroughly inspected and any debris removed. Check to see if they are tightly mounted on the fan shaft and do not rub against the fan housing during rotation. Once every year add 3 drops of SAE 20 weight non-detergent oil to each of the two oil holes on the fan motor if your system is supplied with oil ports.

### Air Distribution

Since all unit models are designed for constant volume air delivery, any unusual air flow restrictions must be avoided. Restricted airflow through the outdoor coil will reduce the operating efficiency of the unit. Additionally, it can result in high compressor head pressure & loss of cooling. In winter, do not permit snow to accumulate around the side or underneath the condenser. Check for bent or damaged coil fins and repair as necessary. Check all refrigerant lines and capillaries for vibration and support as necessary. Carefully inspect all refrigerant lines for signs of oil leaks.

### Refrigeration System

Inspect refrigerant lines every year for signs of wear and proper support. Equipment in normal environments. Depending on the severity of the environment, your equipment may require more frequent service.

Maintenance Item	Monthly	Quarterly/ Seasonally	Semi- Annually	Annually
Check filter	<b>X</b>			
Clean condensate pan and drain		<b>X</b>		
System mounting connections			<b>X</b>	
Tighten wire connections				<b>X</b>
Check refrigerant charge			<b>X</b>	
Blower and motor(s)			<b>X</b>	
Coil(s)			<b>X</b>	
Humidifier (if installed)		<b>X</b>		
Condensate pump (if installed)			<b>X</b>	
Condensing unit		<b>X</b>		
Check wires for wear				<b>X</b>
UV light (if installed)				<b>X</b>

## Trouble Shooting Guide

Symptom	Possible Cause		Possible Remedy
Evaporator Coil Ices	Low airflow	<ol style="list-style-type: none"> <li>1) Dirty filters</li> <li>2) Blower rotating backwards</li> <li>3) Motor speed too low</li> <li>4) Discharge louvers closed</li> </ol>	<ol style="list-style-type: none"> <li>1) replace filters</li> <li>2) reverse rotational wires</li> <li>3) increase motor speed setting</li> <li>4) open louvers</li> </ol>
	Temperature setting too low	<ol style="list-style-type: none"> <li>1) Below minimum temp. set point of 68°F</li> <li>2) Thermostat located in wrong location</li> </ol>	<ol style="list-style-type: none"> <li>1) Increase temp setting</li> <li>2) Move thermostat to measure return air temp.</li> </ol>
	Air short cycling back to return air inlet		Obstruction below discharge louvers
	System low on charge  (also see " <u>Low Suction Pressure</u> " below)	<ol style="list-style-type: none"> <li>1) leak in refrigerant piping</li> <li>2) expansion valve stuck or clogged</li> <li>3) Drier/strainer clogged</li> </ol>	<ol style="list-style-type: none"> <li>1) find and repair leak</li> <li>2) remove and replace or clean valve</li> <li>3) remove and replace drier/strainer</li> </ol>
Low Suction Pressure	System low on charge	<ol style="list-style-type: none"> <li>1) leak in refrigerant piping</li> <li>2) expansion valve stuck or clogged</li> <li>3) Drier/strainer clogged</li> </ol>	<ol style="list-style-type: none"> <li>1) find and repair leak</li> <li>2) remove and replace or clean valve</li> <li>3) remove and replace drier/strainer</li> </ol>
		Inadequate initial charge	Add refrigerant
	Return air temperature setting too low	Below minimum temp. set point of 68°F	Increase temp setting
Condensing temperature too low	Raise condensing temperature above 100°F minimum	Adjust valve on water/glycol systems, fan speed switch on air cooled systems	
Superheat erratic (hunting)	Feeler bulb loose		Tighten feeler bulb to suction line
	TEV partially clogged		Remove, clean and reinstall
	Unit has not operated long enough		Let unit operate for 10-20 minutes to allow superheat to settle down

## Trouble Shooting Continued

Symptom	Possible Cause		Possible Remedy
Condenser pressure too high	Restricted air flow at outside heat exchanger	Debris on condenser coil	Clean debris away; clean condenser
	High static pressure to condenser fan	Low motor RPM	Increase fan motor speed settings
		Condenser fan running in reverse	Reverse fan rotation
	Non-condensable gas in refrigerant system		Recover refrigerant, evacuate system and recharge with new gas
	System over charged		Recover excess refrigerant
	Low water/glycol flow to coaxial condenser		Water regulating valve restricted (see instructions in this manual)
			Drycooler or pump package inoperable
		Drycooler/pump package turned off	Check power; check if on a separate timing circuit.
	Glycol Concentration and/or type is incorrect	Glycol was not premixed before charging system	Remove, mix and refill
		Check glycol to see concentration levels	Dilute to proper ratios
Improper type of glycol used		Remove glycol solution and use correct type (non-foaming)	
Water/glycol regulating valve pressure setting too high		Set pressure to correct psig (see instructions in this manual)	
Condenser fan not operating	Power turned off	Check power; check if on a separate timing circuit.	
	Defective contactor or capacitor	Replace contactor and/or capacitor	
Chilled water valve does not open	Temperature set too high		Lower temperature setting
	Actuator failed		Replace actuator
Chilled water valve does not close	Water pressure differential too high (more than 25 psig)		Change valve for high pressure type (up to 40 psig)
	Actuator failed		Replace actuator

## Trouble Shooting Continued

Symptom	Possible Cause		Possible Remedy
Noisy compressor	Head pressure too high Expansion valve open Liquid "slugging"	See section above for " <u>Condenser pressure too high</u> " Abnormally cold suction line  System over charged	See section above for " <u>Condenser pressure too high</u> "  Feeler bulb loose; tighten  Recover excess refrigerant
Compressor "short cycles"	Dirty or iced evaporator coil  Compressor cycling on high or low pressure switches  Low voltage to compressor  Thermostat in discharge air stream  Light load in the room	   Compressor cycling on internal overloads    Unit capacity is too large for the conditioned space	See "Evaporator Coil Ices" above  See "Low Suction Pressure" and "Condenser pressure too high" above  Check voltage to system and correct  Move thermostat  Install hot gas bypass system Increase heat load
Unit does not start	Control fuse blown  Condensate pan switch is open  Blower relay is defective  Thermostat setting is incorrect		Check power supply to unit for correct voltage Check secondary side of transformer for correct voltage  Check that condensate pan switch is in closed position Ensure unit is level  Replace relay  Put thermostat fan to on position and temperature to "Auto"
Heater does not operate	Thermostat setting too low  Fuses blown  Thermal overload (high voltage fuselink) open  Pilot line overload open  Heater element burned out	Unit does not call for heat  Power on line side of fuses, but not on load side  Heater was too hot (elements are discolored)	Raise temperature setting  Check for short and correct; replace fuses  Determine cause, usually insufficient air flow. Replace fuselink  Replace pilot line overload  Replace heater element

## Trouble Shooting Continued

Symptom	Possible Cause		Possible Remedy
Humidifier inoperative (see humidifier manual for detailed instructions)	Lack of water to humidifier	Water turned off to unit	Water valve closed; open
		Water supply solenoid defective	Replace solenoid valve
	Electrode canister needs replacement	Humidifier turned off in control panel	Turn switch to "Auto" position
		Change cylinder light is on	Replace canister
UV Light does not operate	Safety micro-switch open	Check to see if the contacts are open when the return air grille is closed	Adjust micro-switch to make contact
			Fuses are blown
	Light burned out		Replace light
	Light ballast burned out		Replace ballast

## Dimensional Data

### Self-Contained Air Cooled CM-( )-AS Series

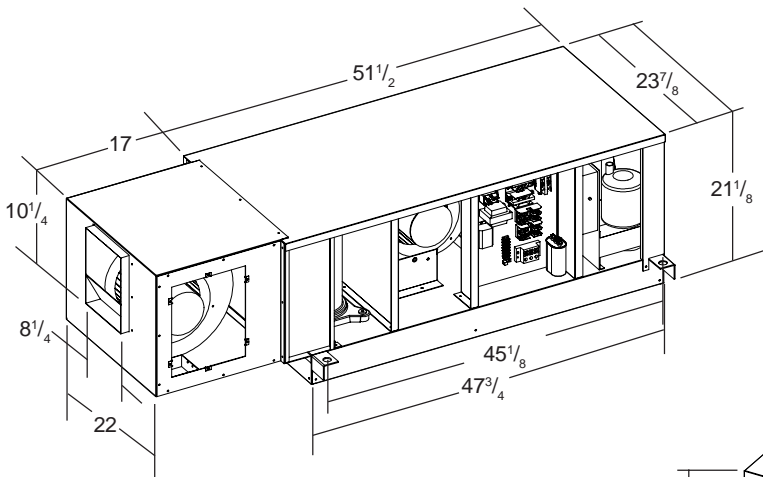

### All Other Units

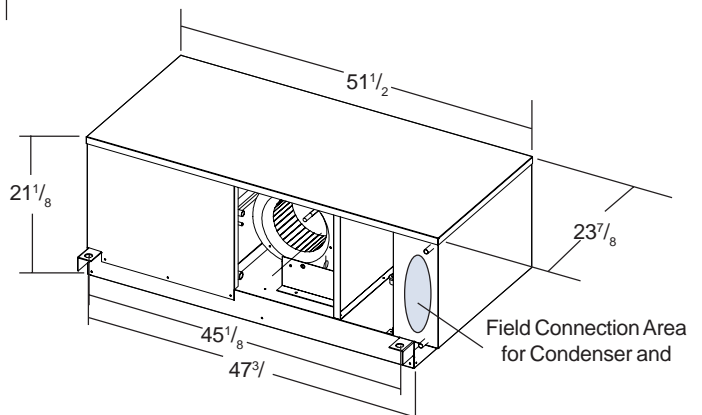

# LIMITED WARRANTY

## **ONE-YEAR WARRANTY:**

- **AeroSys, Inc.** products are warranted to be free from all manufacturing defects, material or workmanship, for a period of one year from the date of purchase (receipt required), whether or not actual use begins on this date; **or** eighteen months from the date of manufacture if the date of purchase cannot be verified.
- A new unit or replacement part for any defective part will be provided without charge, provided the defective part is returned to our distributor or service department following the return instructions below.
- Replacement part will assume the unused portion of the warranty.

## **EXTENDED COMPRESSOR WARRANTY FOR YEARS 2 THROUGH 5:**

- If under normal operation, maintenance and service, the compressor fails due to a manufacturing defect, **Aerosys, Inc.** will provide a replacement new or remanufactured compressor.

## **AEROSYS INC. WILL NOT BE RESPONSIBLE FOR:**

- Cost incurred for repairing, removing, shipping, servicing, installing, or handling of either defective parts or replacement parts.
- Damage or repairs required due to faulty installation or application by others.
- Start failures due to voltage conditions, blown fuses, open circuit breakers, or other damage due to the inadequacy or interruption of electrical service.
- Damage as a result of floods, winds, fires, lightning, accidents, corrosive atmosphere, or other conditions beyond the control of AeroSys Inc.
- Parts not supplied or designated by AeroSys Inc.
- AeroSys Inc. products installed outside the United States and Canada.
- Damage or repairs needed as a consequence of any misapplication, abuse, improper servicing, unauthorized alteration, or improper operation.
- ANY SPECIAL, INDIRECT, CONSEQUENTIAL, PROPERTY, OR COMMERCIAL DAMAGE OF ANY NATURE WHATSOEVER.

## **FOR SERVICE OR REPAIR, FOLLOW THESE INSTRUCTIONS:**

- Contact the installer, or
- Contact the nearest distributor
- A purchase order number is required to ship a replacement part to a customer. The failed part must be returned to AeroSys Inc. with freight prepaid. Credit will be issued to the purchase order/RMA, if the part is found to be a warranty failure.
- Items returned to AeroSys Inc. by installers or distributors for warranty claim must have a Returned Material Authorization Number assigned to and attached to the part. A Returned Material Authorization Number may be obtained by contacting the Service Dept.

## **INSTALLERS / DISTRIBUTORS MUST CALL AND NOTIFY THE FACTORY BEFORE A WARRANTY PART IS RETURNED**

THE FAILED PART MUST BE RETURNED PREPAID WITH THE RETURN MATERIAL AUTHORIZATION NUMBER ON ALL PARTS AND REFERENCE PAPERWORK

### **LIMITATION OF WARRANTIES**

THIS WARRANTY IS EXCLUSIVE & IN LIEU OF ALL OTHER WARRANTIES EXPRESS OR IMPLIED. THE REMEDIES PROVIDED FOR THIS WARRANTY ARE EXCLUSIVE AND SHALL CONSTITUTE THE ONLY LIABILITIES ON THE PART OF AEROSYS, INC.

Model No. \_\_\_\_\_ Serial No. \_\_\_\_\_ Date of Installation \_\_\_\_\_

**Extended duration warranties may apply. Contact your distributor for additional warranty information.**

Effective on all CeilMate™ products manufactured after 9/1/02